

FXM/EJ-N - Spare Parts list

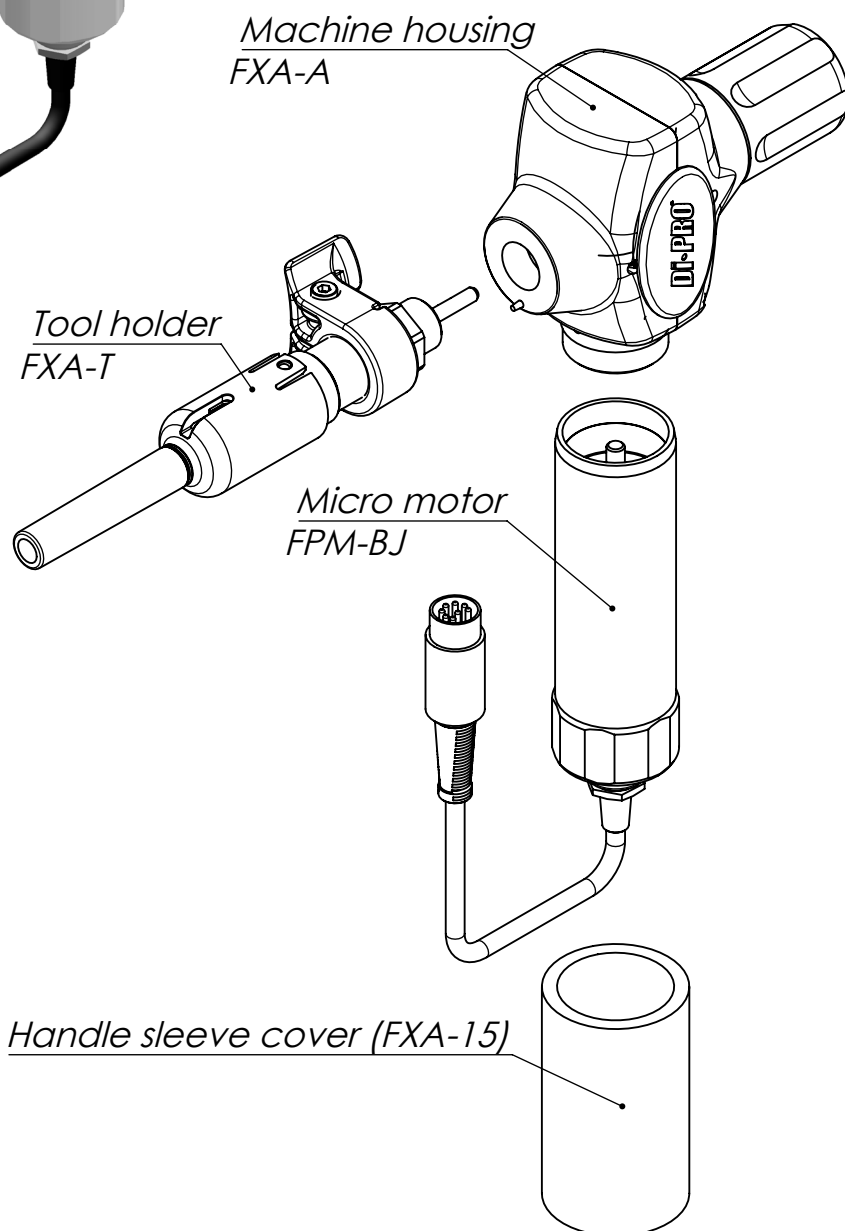

FXA-A - Spare Parts list

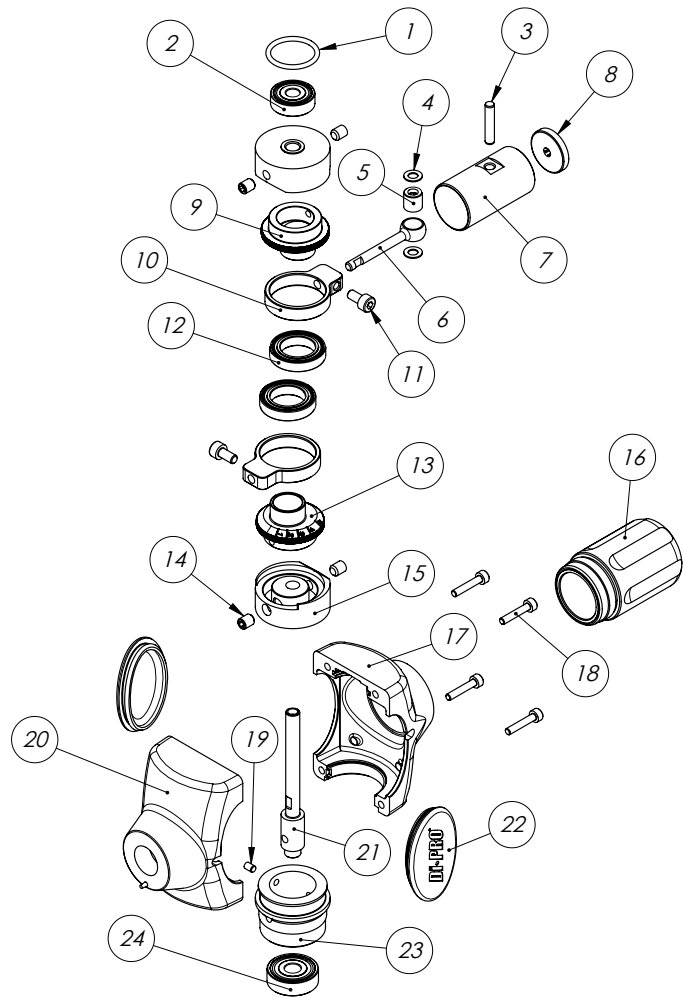

Pos.	Item No.	Description.	Units / machine	Sub-Assembly
1.	60514	O-ring	1	} FXA-U (one piece of FXA-19 included)
2.	44038	Ball bearing	1	
3.	43037	Parallel pin	1	
4.	44043	Washer	2	
5.	44040	Needle bearing	1	
6.	FXA-18	Connecting rod	1	
7.	FXA-108	Counterweight	1	
8.	FXA-19	Counterweight insert	3	
9.	FXA-8/C	Eccentric inner part (for counterweight)	1	
10.	FXA-20	Connecting rod	2	
11.	42057	Screw	2	
12.	44048	Ball bearing	2	
13.	FXA-8/T	Eccentric inner part (for tool-holder)	1	
14.	42055	Screw	4	
15.	FXA-9	Eccentric (outer part)	2	
16.	FXA-16	Counterweight casing	1	
17.	FXA-1	Back Crankcase part	1	
18.	42054	Screw	4	
19.	43027	Parallel pin	1	
20.	FXA-K	Front Crankcase part (incl FNA-25)	1	
21.	FXA-7	Shaft	1	
22.	FXA-3	Rubber cover (for machine housing)	2	
23.	FXA-10	Motor connection	1	
24.	44039	Ball bearing	1	

NOTE! It is recommended to replace both the back and the front crankcase parts (FXA-1 and FXA-K at the same time.

FXA-T - Spare Parts list

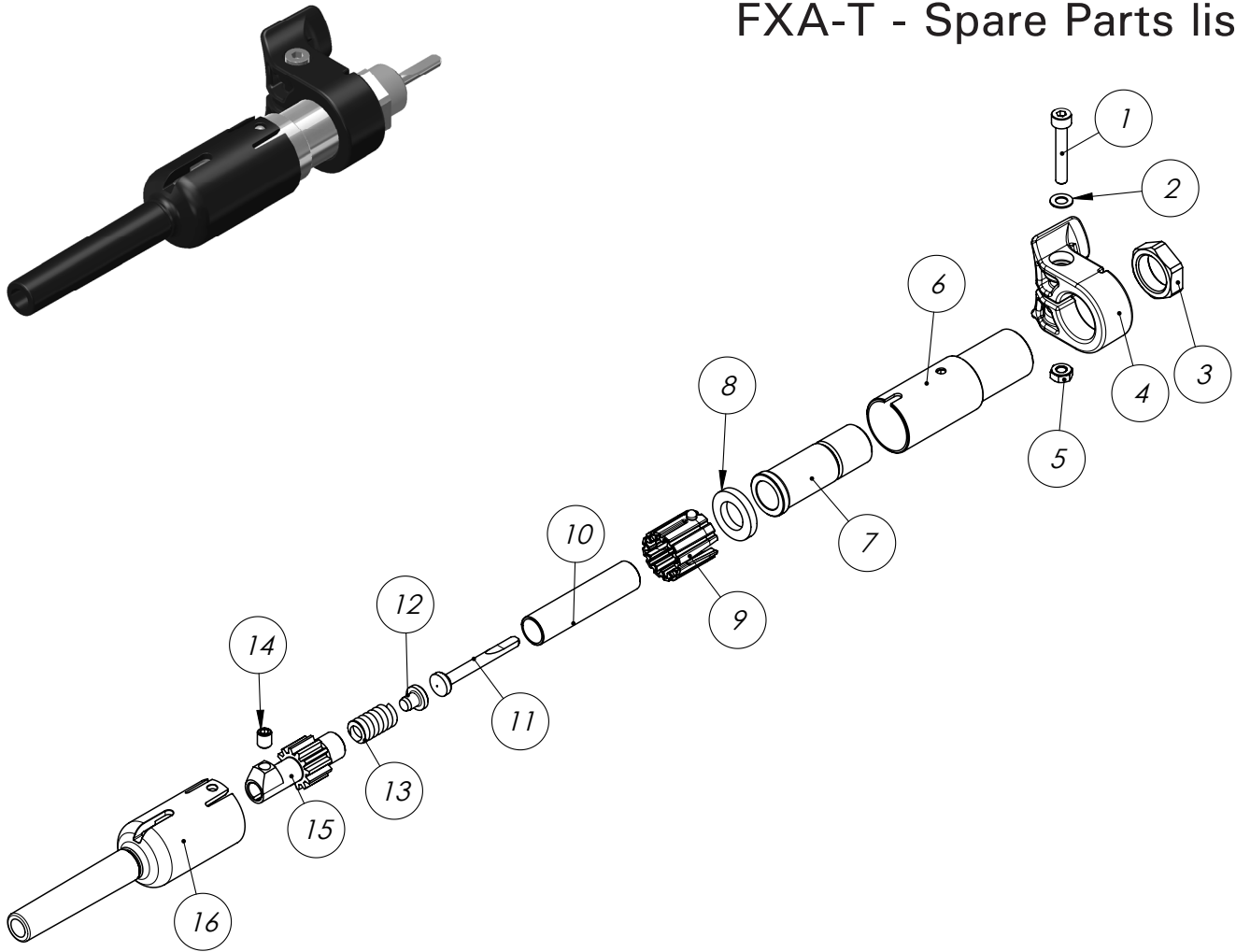

Pos.	Item No.	Description.	Units / machine	Sub-Assembly
1.	42001	Screw	1	
2.	41000	Washer	1	
3.	FNH-21	Retaining nut	1	
4.	FXA-107	Guide block	1	
5.	40000	Nut	1	
6.	FXA-100	Guide sleeve	1	
7.	FXA-102	Supporting sleeve	1	
8.	FXA-106	Lubricating felt	1	
9.	FXA-103	Guide bushing	1	
10.	FXA-105	Piston	1	
11.	FNH-14	Connecting rod	1	FXA-V
12.	FNH-16	Spring insert	1	
13.	FNH-17	Spring	1	
14.	42055	Tool locking screw	1	
15.	FXA-101	Tool holder part	1	
16.	FXA-104	Extension pipe	1	

FPM-BJ - Spare Parts list

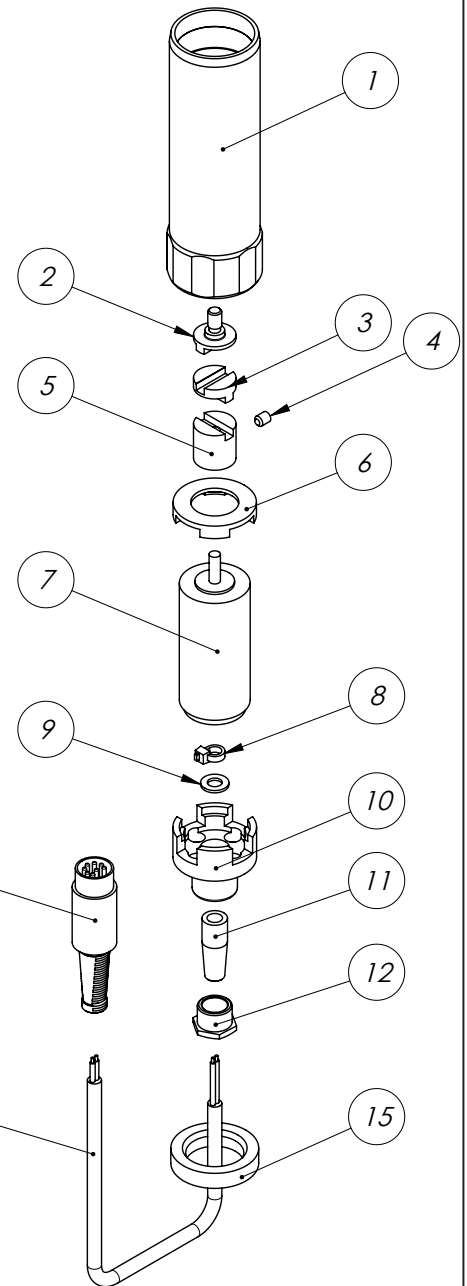
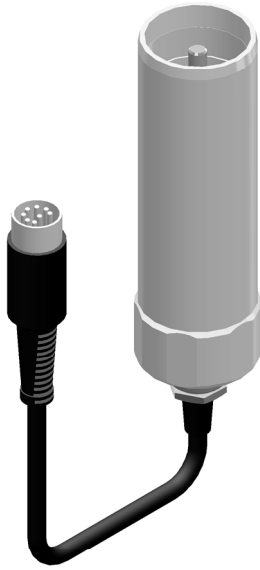

Pos.	Item No.	Description.	Units / machine	Sub-Assembly
1.	FPM-12	Housing	1	
2.	HPN-13	Coupling	1	
3.	HPN-14	Carrier	1	
4.	42025	Locking screw	1	
5.	FPM-15	Coupling	1	
6.	FPM-17	Front support	1	
7.	FPM-10	Micro-motor	1	
8.	49007	Strain relieve	1	
9.	41003	Washer	1	
10.	FPM-18	Back-piece	1	
11.	48006	Protecting sleeve	1	FPM-F
12.	48007	Thrust screw	1	
13.	48033	Connector	1	
14.	49000	Cable	1	
15.	HPN-19	Ring nut	1	