

## INSTRUCTION MANUAL

Thank you for choosing a Diprofil product.

**NOTE!** This product is only compatible with Classic and Di-PRO machines fitted with a 6,4mm tool-holder type FMM-C or FXA-N. It is not compatible with machines fitted with a 3,5mm tool-holder type FPP-C.

### PACKAGE INCLUDES:

- 1 x FXA-V tool-holder including FXA-104 extension pipe
- 2 x FXA-106 spare lubricating felts
- 2 x FXA-103 spare guide bushings
- 2 x 42055 spare tool locking screws
- 1 x SGX-100 maintenance tool
- 1 x SGX-101 maintenance tool
- 1 x SGX-102 maintenance tool
- 1 x 2,5 mm Allen Key
- 1 x 3 mm Allen Key

### THE TOOL-HOLDER EXTENSION PIPE:

The machine comes with an included tool-holder extension pipe (FXA-104). The extension pipe will facilitate the use of longer tools as it will still be possible to guide the tool close to the working surface without the need for putting your fingers on moving tools and/or machine parts. The extension pipe can easily be cut to the desired length to suit different tools.

To assemble the extension pipe simply push it onto the tool-holder making sure that it is locked in position by the small plastic knobs on the actual tool-holder.

To remove the extension pipe, twist it slightly and pull it off.

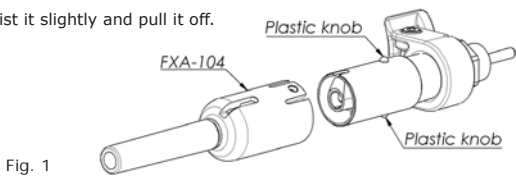

The following instructions will be helpful when replacing/upgrading the tool-holder on your current Classic- or Di-PRO machine.

### CLASSIC MACHINES

1. Remove the machine cover (FMM-3). **NOTE!** Never operate the machine without the machine cover.
2. Loosen the connecting rod screw (42053).
3. Release the piston rod and tool-holder (FNH-G) and attached parts by sliding it out of the machine housing.
4. Loosen the retaining nut (FNH-21) by means of a 19mm hexagonal spanner.
5. Unscrew/separate the tool-holder from the machine housing.

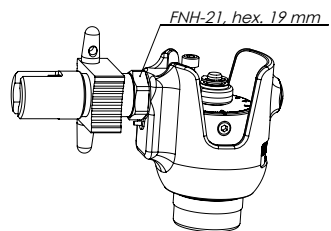
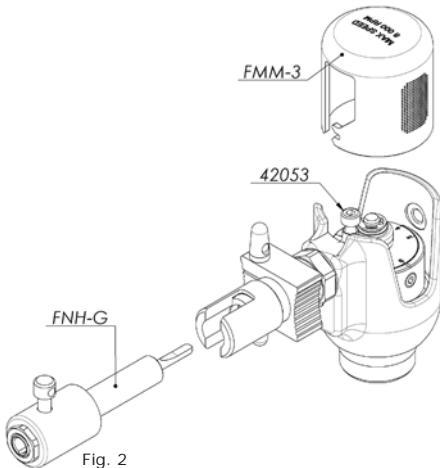

6. Assemble the new tool-holder and lock it into place with the retaining nut (FNH-21) by means of a 19mm hexagonal spanner. It's important not to tighten the actual tool-holder too much against the machine housing before locking it with the retaining nut (FNH-21) as this will make it impossible to use the tool-holder in its swivelling mode.
7. Slide the piston rod and tool-holder (FXA-V) into the machine housing, making sure that the piston rod goes all the way to the bottom of the linkage (FNE-102). Then lock it into place with the connecting rod screw (42053).
8. Reassemble the machine cover.

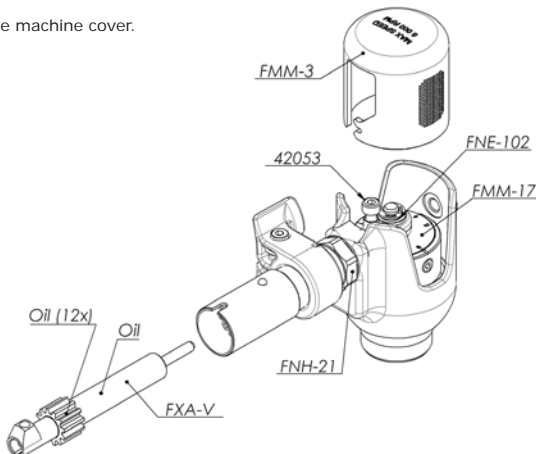

## DAILY MAINTENANCE:

The below procedure should be carried out approximately every 8 hours of operation.

1. Remove the Machine cover (FFM-3).
2. Apply a few drops of lubrication oil, type Diprofil FNA-K or equivalent, to the needle bearing in the linkage (FNE-102) approximately every 8 hours of operation.
3. Loosen the connecting rod screw (42053).
4. Release the piston rod and tool holder (FXA-V) by sliding it out of the machine housing.
5. Clean the piston rod and tool holder (FXA-V) carefully with a soft cloth and apply a few drops of lubrication oil, type Diprofil FNA-K or equivalent, according to fig 5 and 6.
6. Reassemble the piston rod and tool holder (FXA-V) into the machine housing, making sure that the piston rod goes all the way to the bottom of the linkage. Lock it with the connecting rod screw (42053).
7. Reassemble the machine cover (FMM-3).

See Fig. 5

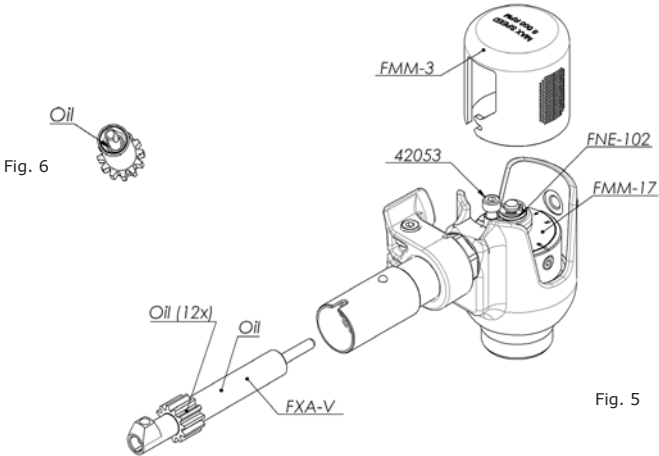

Fig. 5

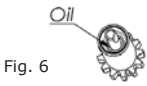

Fig. 6

## REPLACEMENT OF THE LUBRICATING FELT AND THE PLASTIC GUIDE BUSHING.

1. Remove the machine cover and the piston rod and tool-holder according to the description for daily maintenance.
2. Slide the tool (SGX-102) onto the tool-holder.
3. Squeeze/compress the tool (SGX-100) and put it inside the tool-holder making sure that it gets a sufficient grip of the guide bushing (FXA-103).
4. Make sure that the 2 screws (42000) are perfectly aligned with the plastic knobs on the actual tool-holder. Tighten both screws all the way to the bottom by means of a 2,5 mm Allen-key to release the guide bushing (FXA-103) from the outer sleeve of the tool-holder.
5. Then pull the guide bushing out of the tool-holder.
6. Remove the old lubricating felt (FXA-106) and replace it with a new one (make sure that it is drenched in oil, type Diprofil FNA-K or equivalent).

See Fig. 7

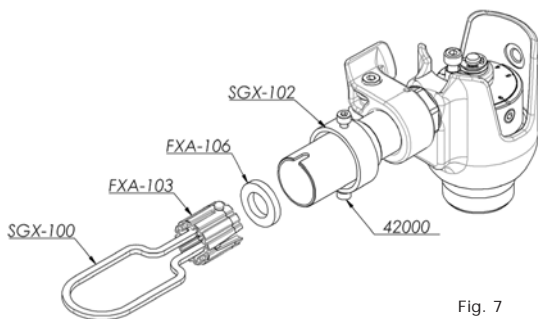

Fig. 7

7. Squeeze/compress the new guide bushing (FXA-103) and press it about 5 mm into the tool-holder (the knobs should be pointing inwards and towards the machine housing).
8. Then push it all the way to the bottom by means of the tool (SGX-101) making sure that both the plastic knobs are popping out of the small holes on the outer sleeve of the tool-holder. If you are experiencing problems with aligning the knobs with the holes, use the tool (SGX-100) to swivel the guide bushing until they become aligned and the knobs pop out of the holes.
9. Reassemble the machine cover and the piston rod and tool-holder according to the description for daily maintenance.

See fig. 8

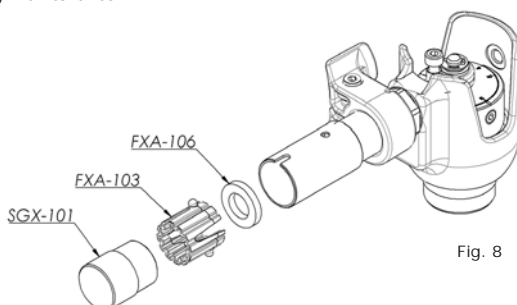
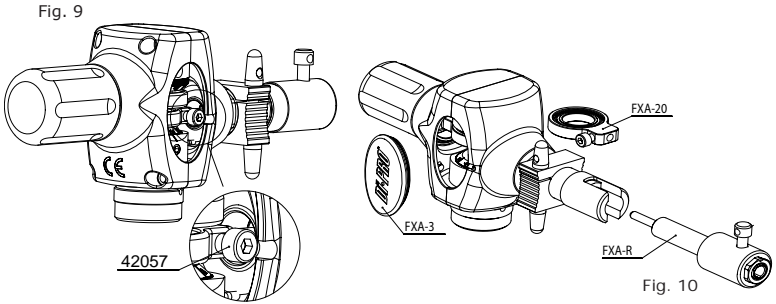

Fig. 8

**DI-PRO MACHINES**

1. Remove both the rubber covers (FXA-3). **NOTE! Never operate the machine without the machine covers.**
2. Loosen the connecting rod screw (42057) on the lower connecting rod (FXA-20). **Please make sure not to loosen the screw too much (1 turn is sufficient enough).**
3. Release the piston rod and tool-holder (FXA-R) and attached parts by sliding it out of the machine housing.



4. Loosen the retaining nut (FNH-21) by means of a 19mm hexagonal spanner.
5. Unscrew/separate the tool-holder from the machine housing.

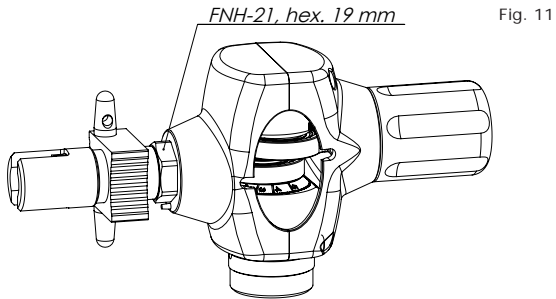

6. Assemble the new tool-holder and lock it into place with the retaining nut (FNH-21) by means of a 19mm hexagonal spanner. It's important not to tighten the actual tool-holder too much against the machine housing before locking it with the retaining nut (FNH-21) as this will make it impossible to use the tool-holder in its swivelling mode.
7. Slide the piston rod and tool-holder (FXA-V) into the machine housing, making sure that the piston rod goes all the way to the bottom of the lower connecting rod (FXA-20) and lock it into place with the connecting rod screw (42057).
8. Reassemble both the rubber covers (FXA-3).

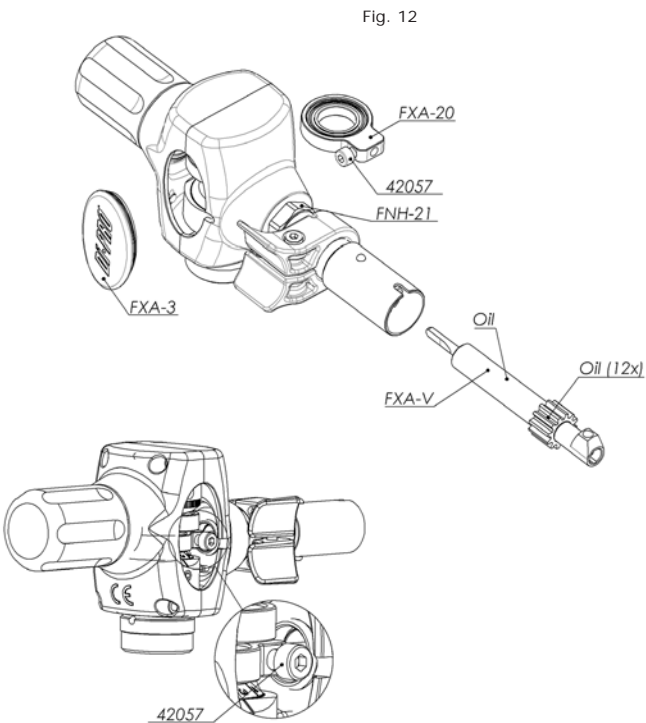

**REPLACEMENT OF THE LUBRICATING FELT AND THE PLASTIC GUIDE BUSHING.**

Please see the description for the Classic machine above.

## DAILY MAINTENANCE

1. Remove both the rubber covers (FXA-3).
2. Loosen the connecting rod screw (42057) on the lower connecting rod (FXA-20).  
**Please make sure not to loosen the screw too much.**
3. Release the piston rod and tool-holder (FXA-V) by sliding it out of the machine housing.
4. Clean the piston rod and tool-holder (FXA-V) carefully with a soft cloth and apply a few drops of lubrication oil, type Diprofil FNA-K or equivalent, according to fig.14 and 15.
5. Reassemble the piston rod and tool-holder (FXA-V) into the machine housing, making sure that the piston rod goes all the way to the bottom of the lower connecting rod (FXA-20) and lock it into place with the connecting rod screw (42057).
6. Reassemble both the rubber covers (FXA-3).

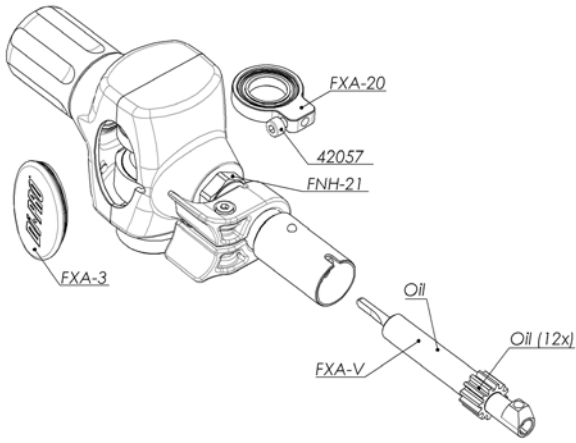

Fig. 14

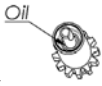

Fig. 15